



Item No. _____
 Project _____
 Quantity _____

BakerSeries Semi-Automatic Bun & Roll Divider Rounder

MODEL: BRD - Series



Model BRD-36-3 shown

PAN & PRODUCTION CAPACITY GUIDE

Capacity / Model	BRD-36-3	BRD-36-4
Maximum Load	6 Lb. - 12 oz.	9 Lb.
Minimum Load	2 Lb.	3 Lb. - 5 oz.
Yield - 36 parts	7/8 to 3 oz.	1.5 to 4 oz.

Short Bid Specification:

Divider/Rounder shall be LBC Bakery Equipment, Model BDR- [insert model number], Semi-automatic Bun and Roll Divider/Rounder, with rugged cast iron base and easily removable pressure head and knives. Head section shall be fitted with dual hinges to allow head opening in two directions. Head pins shall be one inch (1") diameter, with cross pin handles and shall be clearance fitted for easy removal. Head sections shall be cast aluminum and shall be removable without tools. Knives shall be stainless steel and shall be removable without tools. Dough-guide ring shall be stainless steel. Divider/Rounder shall be supplied with three (3) plastic dividing plates. Divider/Rounder shall be MET and BISSC approved for safety and sanitation.

STANDARD PRODUCT WARRANTY

One-Year Parts and 90 Days Labor (contiguous US Including Alaska and Hawaii, Canada)

Construction Features

- . Heavy duty cast iron base
- . Heavy duty 3 phase motor
- . Easy opening, dual-direction hinged head
- . Bolt-down flange base
- . Rugged PVC removable hoods
- . Cast aluminum pressure plates
- . Cast Iron orbiting platen
- . Stainless steel dividing knives
- . Stainless steel dough-guide ring
- . Easy access molding lever
- . Floating dough guide ring

Performance Features

- . Oil-less press and knife design
- . 1 HP rounding drive motor
- . Heavy duty press lever with counter-weight
- . Adjustable knife pressure
- . Variable exocentric-action rounder
- . Quick removal knives and head (no tools)
- . Permanently lubricated oil-bath transmission

Controls Features

- . Bush button motor start-stop
- . 30" Knurled pressure lever
- . Front-mounted knife release lever
- . Extended front-mounted rounding lever
- . Counter balanced press lever



Sheet Number BRD-RR1 (rev 06/06)

Food Makers Bakery Equipment

16019 Adelante Street Irwindale, CA 91702

Phone: 626-358-1343 FAX: 626-334-0970

Sales@fmebakery.com

www.fmebakery.com

BakerSeries Semi-Automatic Bun & Roll Divider Rounder

MODEL: BRD

INSTALLATION REQUIREMENT

Electrical: 208 or 240 VAC, 3-Phase, 15 Amp, NEMA L15-20 Receptacle

STANDARD COMPONENTS: 3 plastic rounding platens, 30" press handle, 6' type SO power cord

OPTIONS & ACCESSORIES: Additional plastic rounding platens, Aluminum rounding platens

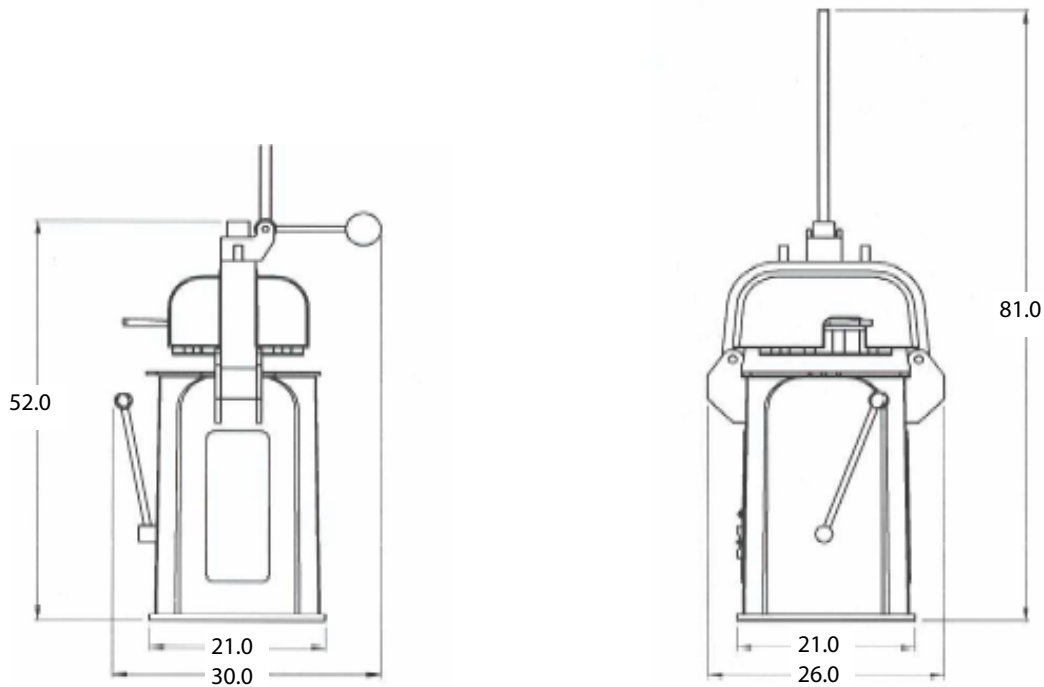

Model	Dimensions	Clearance		Weight		Freight Class
	Height x Width x Depth	Sides	Back	Actual	Shipping	
BRD36-3	81 (57) x 26 x 30	30" either side	0"	775	850	70
BRD36-4	81 (57) x 26 x 30	30" either side	0"	775	850	70



Food Makers Bakery Equipment

16019 Adelante Street Irwindale, CA 91702

Phone: 626-358-1343 FAX: 626-334-0970

Sales@fmebakery.com

www.fmebakery.com